



H32DESIGN

ASSEMBLY INSTRUCTIONS

Spare wheel ladder

Sprinter 906 / 907 / Crafter 1

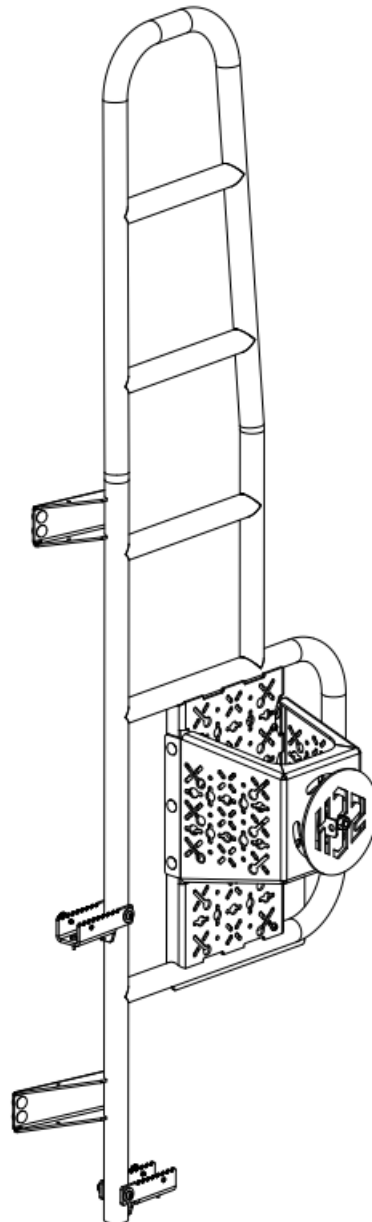

1. GENERAL

The ladder will be attached to the two hinges of the rear door and fixed with two additional screws through the door panel.

2. REQUIRED TOOLS

Cordless screwdriver
Reversible ratchet with a 10mm & 13mm socket wrench insert
Screw driver Tory TX25
Step-drill or 4mm & 7mm drill
Deburrer or countersink
Zinc spray
Small brush

IPA cleaner
Cleaning wipes
Tape
Marker
Glue (z.B. Sika 252)
Sealing (z.B. Dekaseal 8936)
19er Gabelschlüssel
Thread lock (z.B. Loctite)

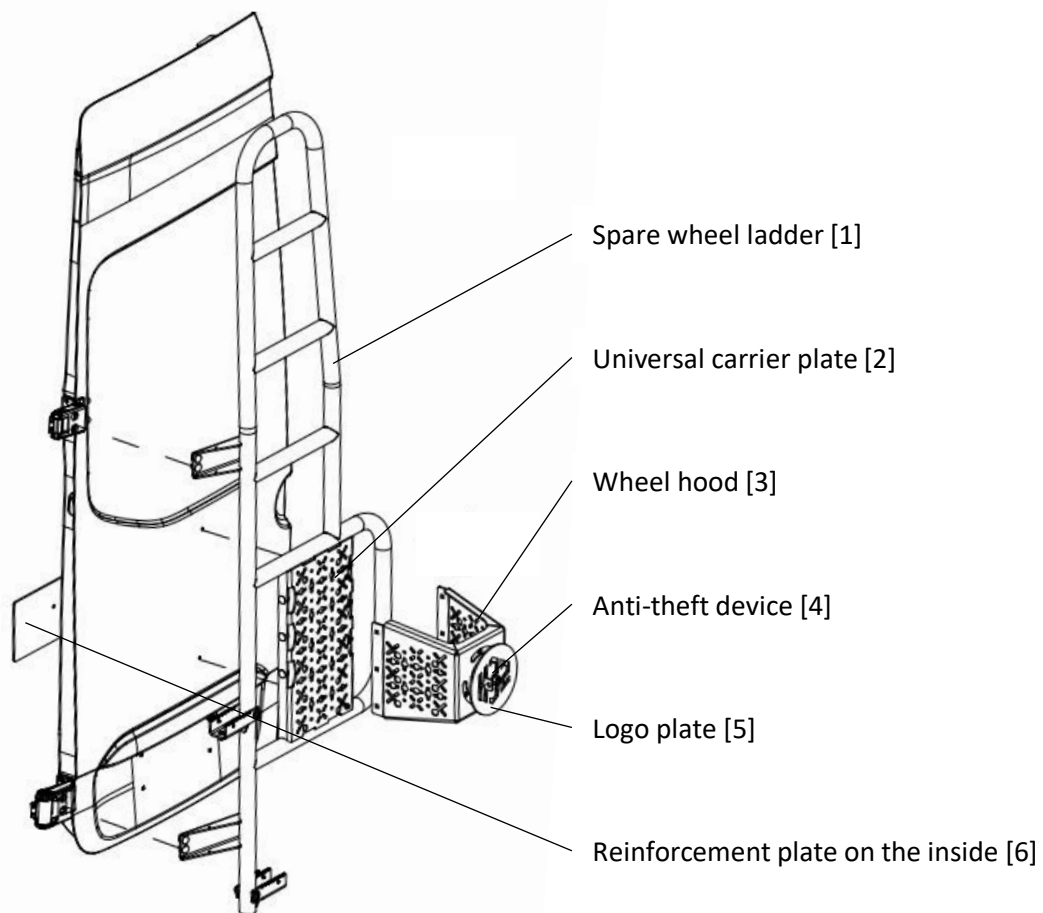

3. CHECKING THE SCOPE OF DELIVERY

Unpack everything and check the scope of delivery for completeness and transport damage.

4. REMOVE DOOR COVERS

Open the rear door and remove the covers on the inside of the door.

5. TEST ASSEMBLY

Test fit the ladder with one screw per hinge. Adjust the position of the ladder so that the holes in the hinges line up with the holes in the side arms of the ladder.

6. MARK THE THIRD AND FOURTH MOUNTING POINT

Mark the two additional mounting points in the door panel by sticking tape onto the door panel and mark the screw position with a marker through the defined position on the universal carrier plate [2] (Detail A & B).

Tip: Check on the inside of the door where the screws will come out and make sure that you can glue in a reinforcement plate there. And make sure you are able to reach them for fastening afterwards.

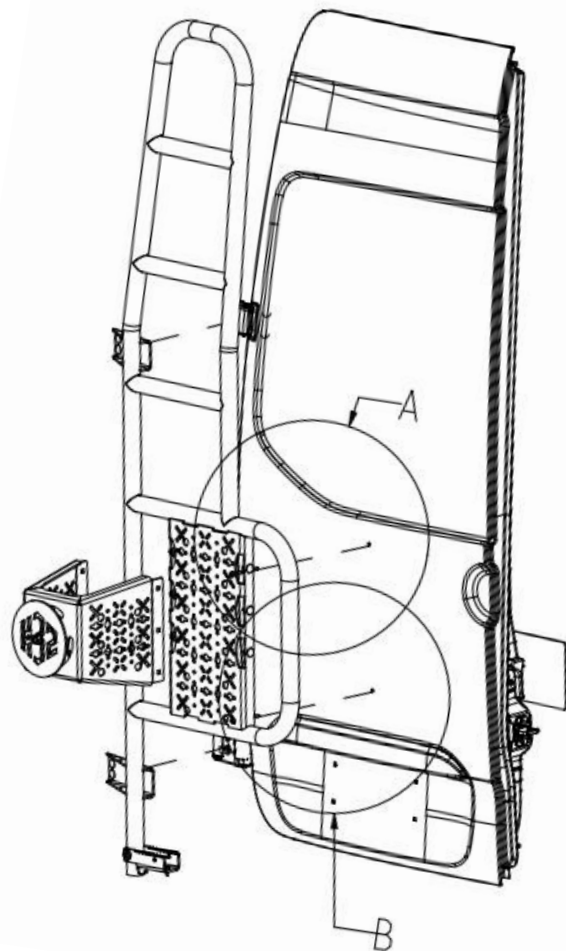

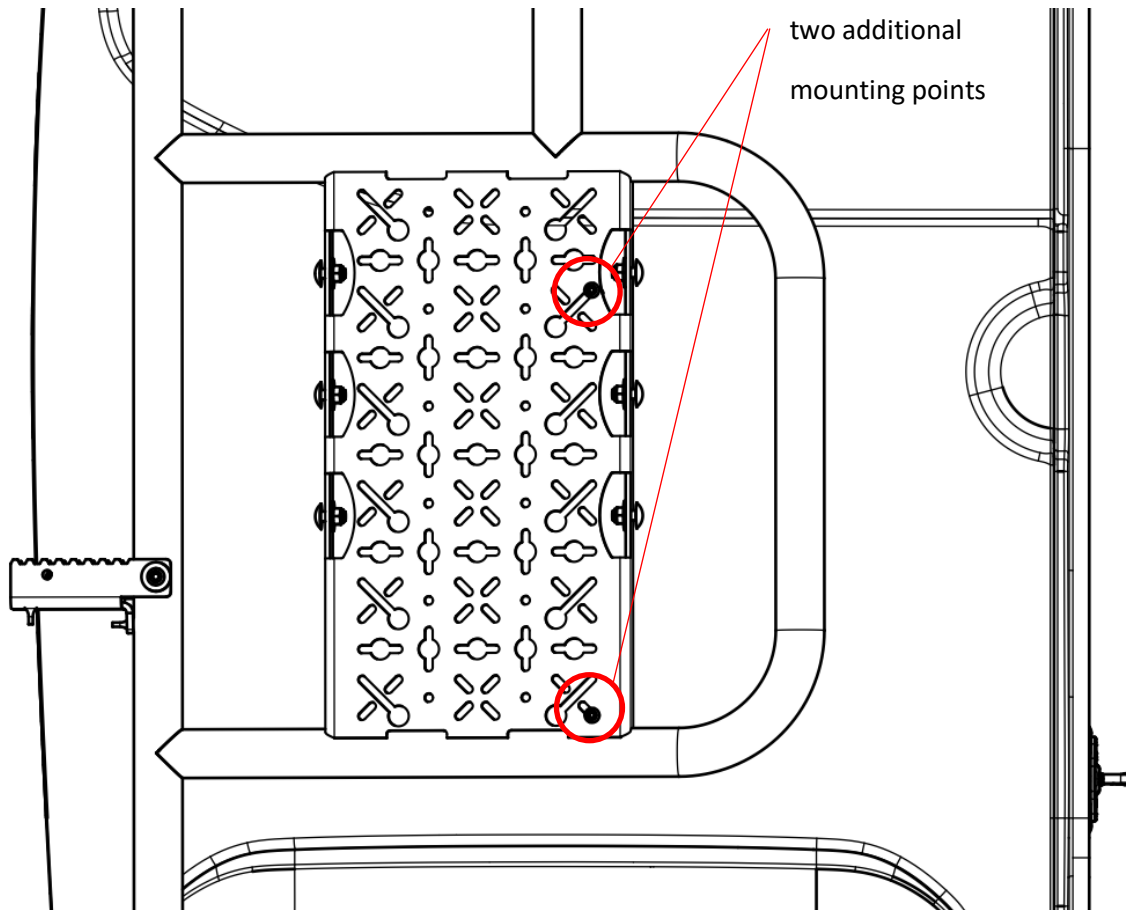

7. DRILL THE TWO ADDITIONAL MOUNTING POINTS

Remove the ladder again and put it aside. Drill the two marked mounting points into the door sheet metal.

Tip: start with a 4mm drill, then widen it with a 7mm drill.

Deburr the hole inside and outside with a deburrer or a countersink. Then apply zinc spray to the hole edge to protect them against rust. The best way to do this is using a small brush.

Then also drill the reinforcement plates. Hold them to the inside area of the hole and mark the hole from the outside (also use a 7mm drill for the reinforcement plates).

Clean them with IPA cleaner.

8. GLUE THE REINFORCEMENT PLATE ON THE INSIDE OF THE DOOR

While the zinc spray dries you can use the glue (Sika 252) to stick the reinforcement plates to the inside of the door. Make sure the hole in the door and the hole in the reinforcement plate line up (clean all gluing areas with IPA cleaner before adding the glue).

9. ATTACH THE LADDER

Mount the ladder again by adding the screws to the hinges. Just tighten the screws slightly so you are still able to adjust the position.

To make sure the distance between ladder and door will stay the same add the rubber spacers which are part of the delivery scope (3pcs. for each mounting point).

Mount the ladder to the two additional mounting points by using the M6 Screw (120mm). Put the screw through the universal carrier plate, then the rubber spacer and then through the hole in the door sheet metal. For a perfect sealing add a bit of sealant (Dekaseal 8936) to the rubber spacer which is next to the door sheet metal (fill up the spacer with Dekaseal before you put in the screw).

Now you can add the washer and nut on the inside of the door and tighten it up.

Also tighten all 4 screws in the hinges.

Check if the ladder has a good and safe fit and make sure everything is tightened properly.

10. WHEEL HOOD PREPERATION

Add a few drops of thread lock to the M12 bolt and screw it into the center hole of the rim-bracket.

Insert the rim bracket into the wheel hood from the inside. Then put the anti-theft bracket on the front and fasten everything with the M12 nut. The anti-theft bracket must have the same orientation as in the picture below. So the logo plate will fit on it later.

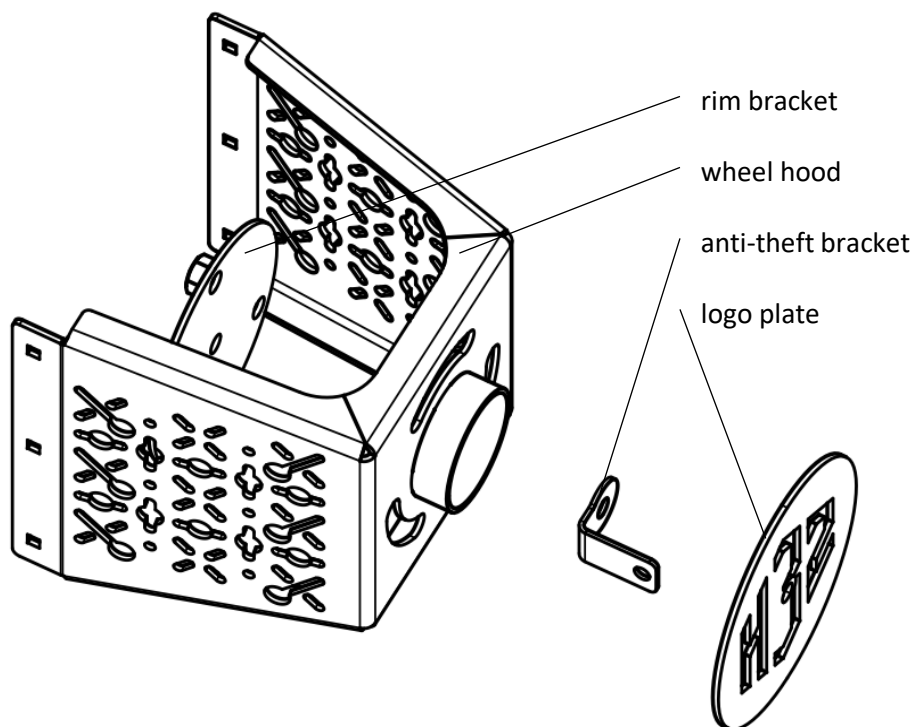

11. ATTACHING THE WHEEL HOOD

Mount the wheel hood with 6 pcs. screws on the side of the ladder base.

12. ATTACH THE SPARE WHEEL

Now you can lift your spare wheel onto the wheel hub of the wheel hood and fasten the rim with 3 wheel bolts.

Put the logo plate on it and fasten it with another M12 nut.

Tip: Hang a padlock through the anti-theft bracket so the spare wheel cannot be stolen. With the padlock the logo plate can not be removed and the wheel bolts remain inaccessible.

13. MOUNT THE HINGE COVERS

Mount the hinge covers on each ladder support arm by using the self-tapping M4 screws (TX25).

The H32 Team wishes you lots of fun on your travels. We hope that our products will bring you a lot of joy and added value. We look forward to your feedback. Feel free to contact us with positive or negative feedback or questions by email: office@h32-design.com